

## D-Link ANT24-1800

# High Gain Directional Panel Antenna



- **18 dBi Signal Gain**
- **2.4GHz Frequency Range**
- **Directional Orientation of Antenna**
- **Includes Cable that Converts N-Female to Reverse SMA**
- **Made with Weatherproof and Corrosion Resistant Material**

## Outdoor 18 dBi High Gain Directional Panel Antenna

The D-Link ANT24-1800 connects to the DWL-900AP+, DI-614+, DI-714P+, DWL-900AP, DI-714 and DI-713P to extend the range of coverage for the wireless network.

The D-Link ANT24-1800 antenna provides extended coverage for an existing 802.11b wireless local area network (WLAN). The D-Link ANT24-1800 comes with a conversion cable that allows connection directly to the DWL-900AP+ wireless access point, DI-614+ wireless router, DI-714P+ wireless router, DWL-900AP wireless access point, DI-714 wireless router and the DI-713P wire-

less router Rev C1 or later wireless broadband router.

This product includes the following items: Mounting Kit, Lightning Surge Protector, Conversion Cable.

The D-Link ANT24-1800 requires an access point or wireless broadband gateway with a reverse SMA connector.

*Note: To obtain optimal results in extending wireless range with outdoor antenna installations, it is recommended that professional installer service is consulted for site survey and and proper installation.*

### The D-Link ANT24-1800 Includes

Antenna  
Manual  
Mounting Kit  
Conversion Cable  
Lightning Surge Protector

## Technical Specifications

### Electrical Specifications

**Frequency Range**  
2.4-2.5GHz

**Gain**  
18 dBi

**VSWR**  
1.5:1 Max

**Polarization**  
Linear, vertical

**HPBW**

- horizontal - 15°
- vertical- 15°

**Power Handling**  
50W (cw)

**Impedance**  
50 Ohms

**Connector**  
N female

**Cable**  
(N-male to RP-SMA plug) - 1.5 feet -  
0.83db lost per meter

**Front to Back Ratio**  
26dB

### Environmental & Mechanical Characteristics

**Temperature**  
-40°F to 176°F (-40°C to 80°C)

**Humidity**  
100%@ 77°F (25°C)

**Lightning Protection**  
DC ground

**Radome Color**  
White

**Radome Material**  
ABS, UV Resistant

**Weight**  
7.16 lbs (3.25kg)

**Dimensions**  
12.6 x 12.6 x 0.63 in. (360 x 360 x 16 mm)

**Survival Wind Speed**  
112 miles/hr (180 km/hr)

**Housing Material**  
Galvanized Iron Fire Retardant

**Warranty**  
1 Year

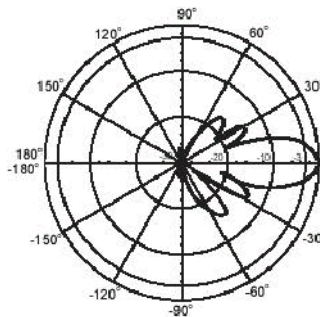

Horizontal

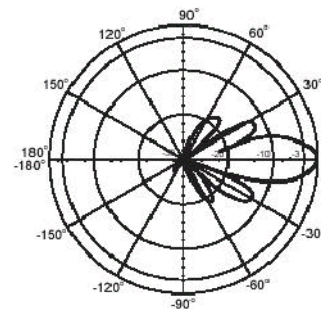

Vertical

